



Rám určený do zděné příčky pro závěsná WC
Mounting frame for wall hung toilet

(CZ) Montážní návod (RU) Инструкция по монтажу (RO) Instrucțiuni de montaj (NL) Montage instructie
(SK) Montážny návod (D/A) Montageanleitung (ES) Manual de instrucciones (LT) Montavimo instrukcija
(GB) Mounting instructions (PL) Instrukcja montażu (FR) Notice de montage

(CZ) Specifikace dodávky (RU) Спецификация поставки (RO) Componente livrate (NL) Leveringsomvang
(SK) Špecifikácia dodávky (D/A) Lieferumfang (ES) Especificación de suministro (LT) Tiekimo specifikacija
(GB) Supplied equipment (PL) Specyfikacja dostawy (FR) Equipements fournis

SLR 03 - Obj. č. (Code Nr.) - 08030

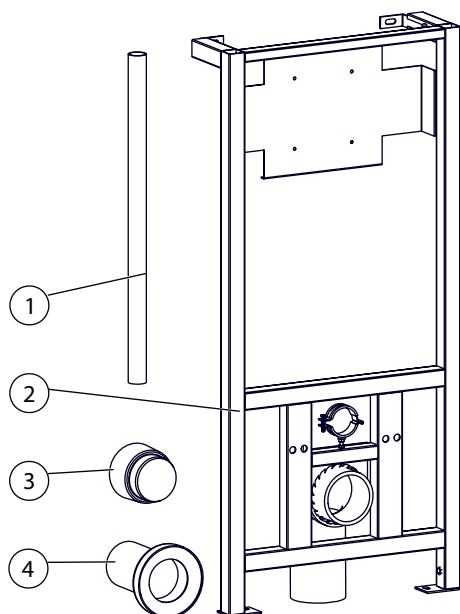

Pozice / Position	Obj. číslo / Order num.	Počet / Quantity
1	45390	1
2	45549	1
3		1
4		1
5		4
6		4
7		4
8		4
9		4
10		45812
11	45796	2
12	45790	2
13	45549	2
14		2
15		2
16	47334	2
17	45549	2
18		2
19	44645	1
20	45281	1
21	45549	2
22		2

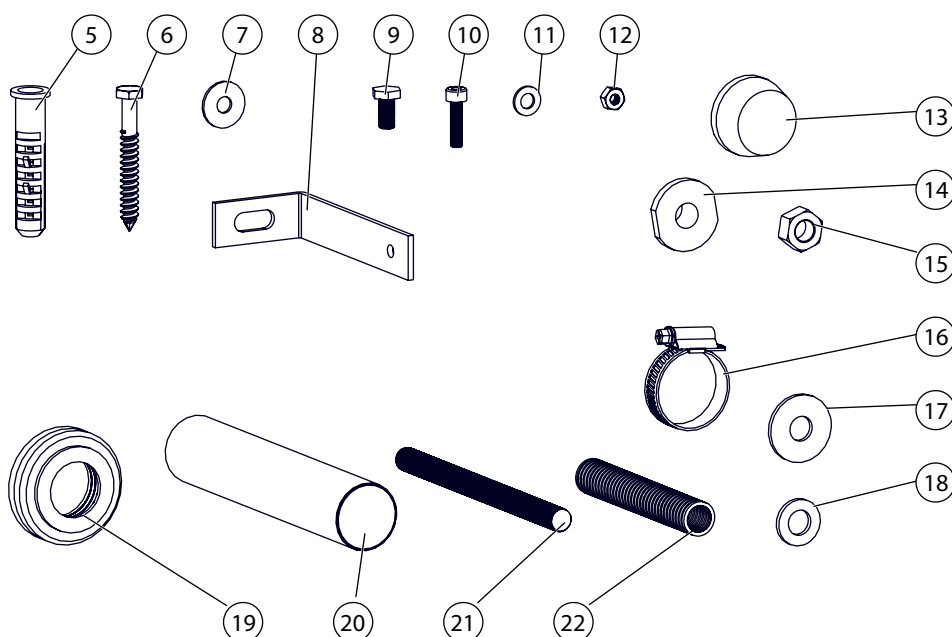

ⒸZ Rozměry
ⒸSK Rozměry
ⒸGB Dimensions

ⒸRU Размеры
ⒸD/A Abmessungen
ⒸPL Rozmiary

ⒸRO Dimensiuni
ⒸES Dimensiones
ⒸFR Dimensions

ⒸNL Afmetingen
ⒸLT Dydis

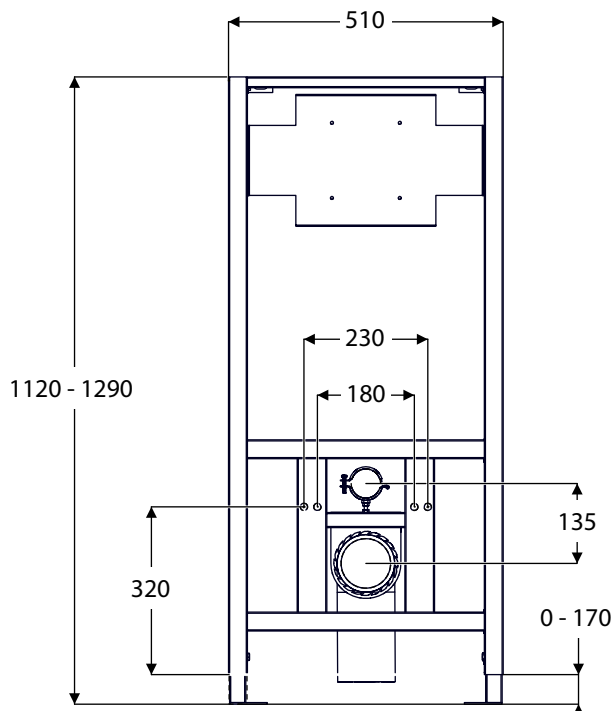
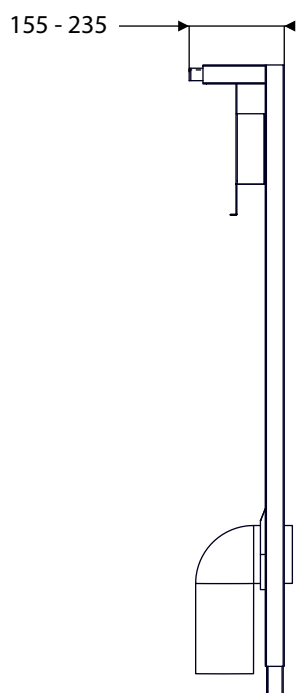

ⒸZ Instalace
ⒸSK Inštalácia
ⒸGB Installation

ⒸRU Схема включения и монтажа
ⒸD/A Installation
ⒸPL Instalacja

ⒸRO Instalare
ⒸES Instalación
ⒸFR Installation

ⒸNL Installatie
ⒸLT Montavimo ir įjungimo schema

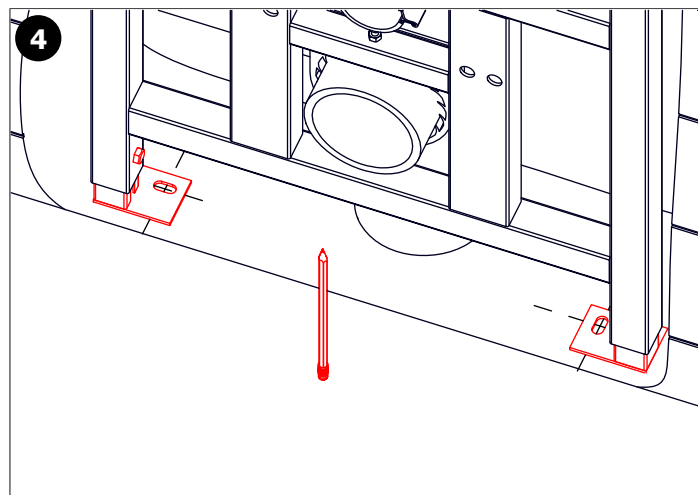
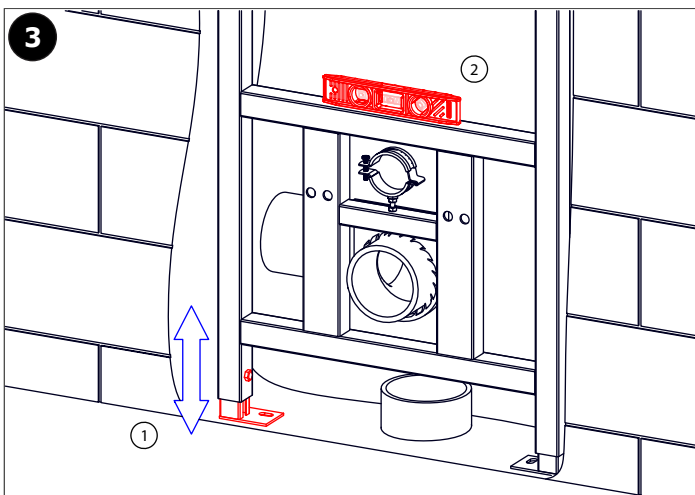
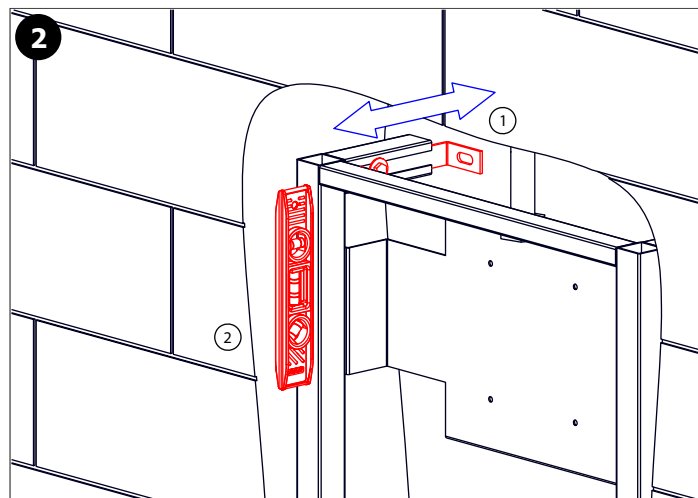
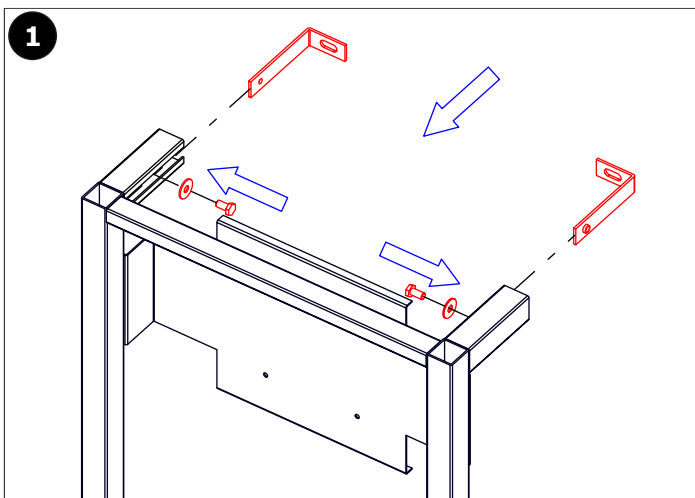

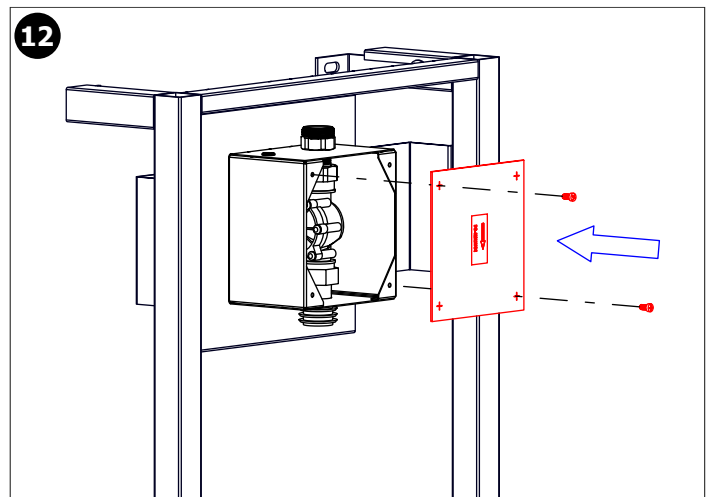
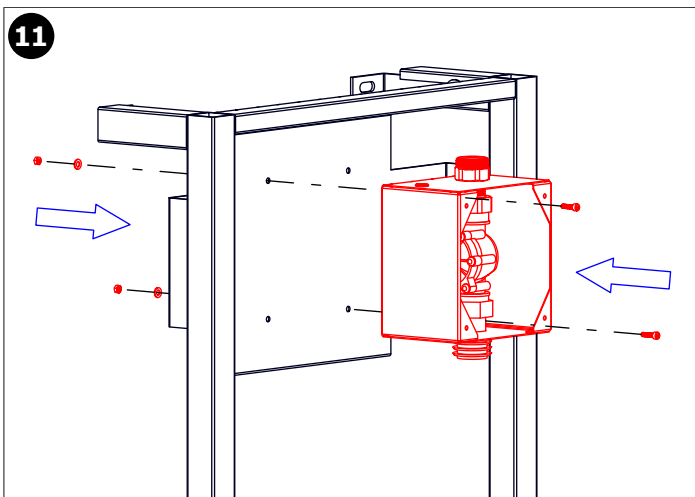
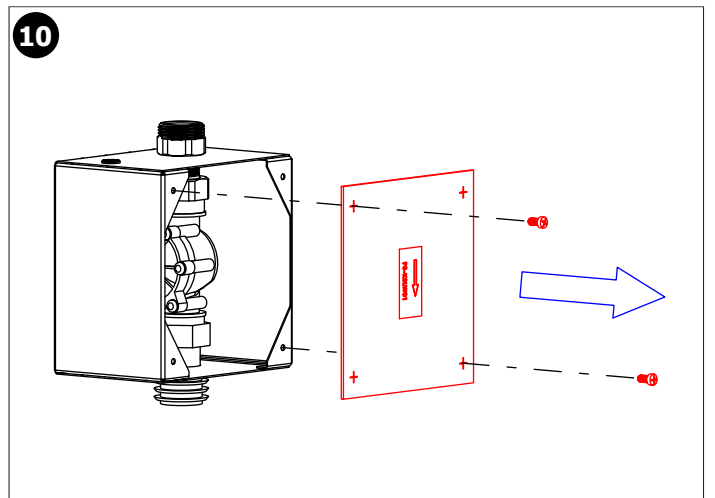
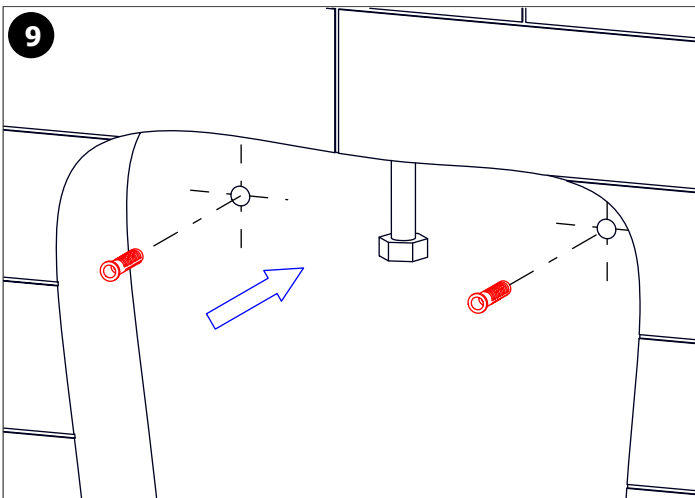
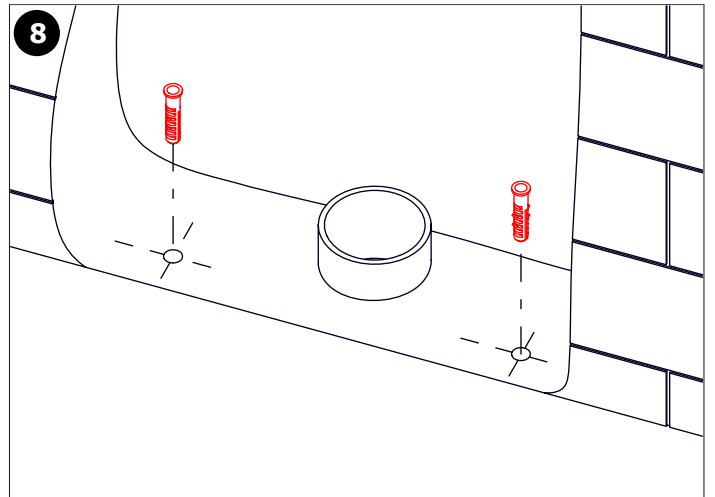
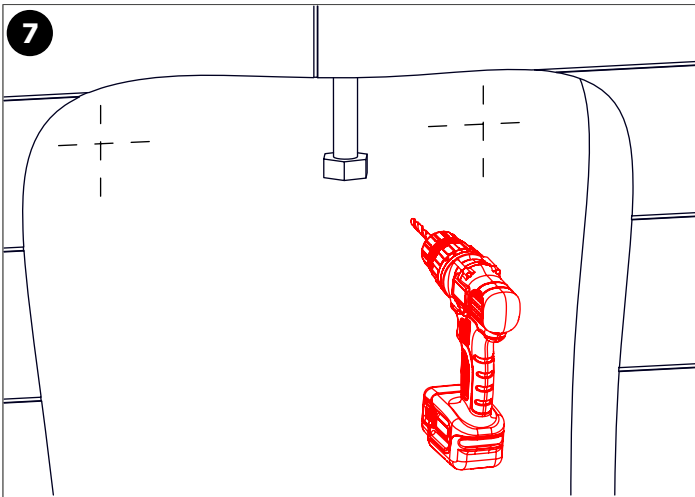
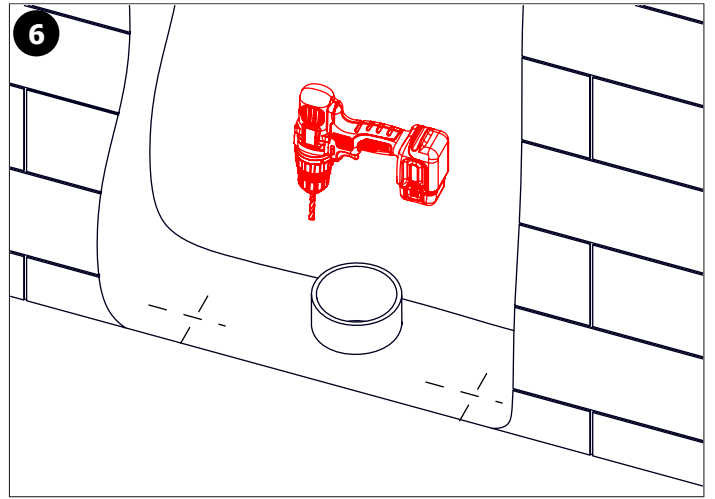
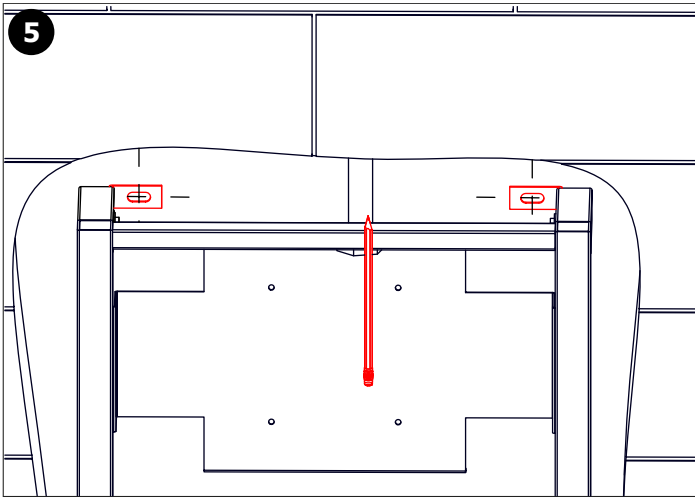

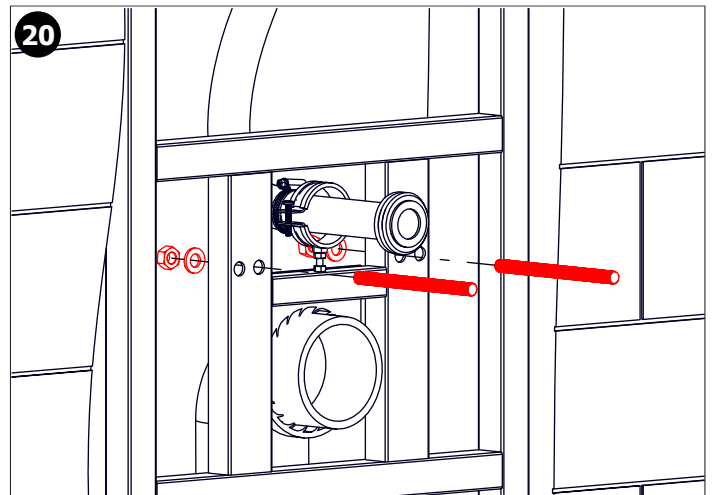
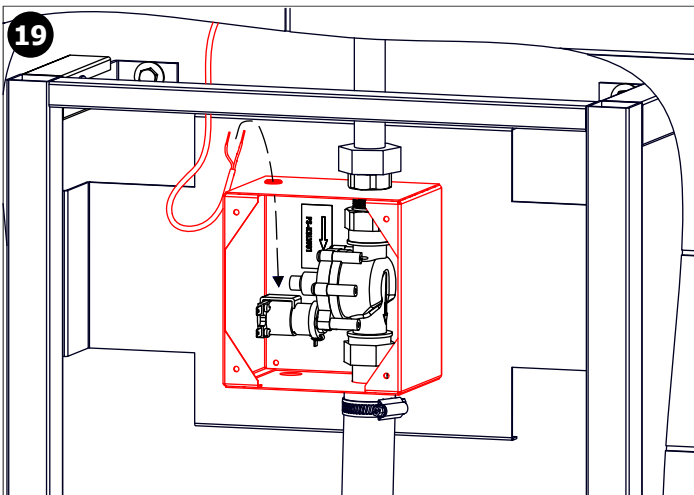
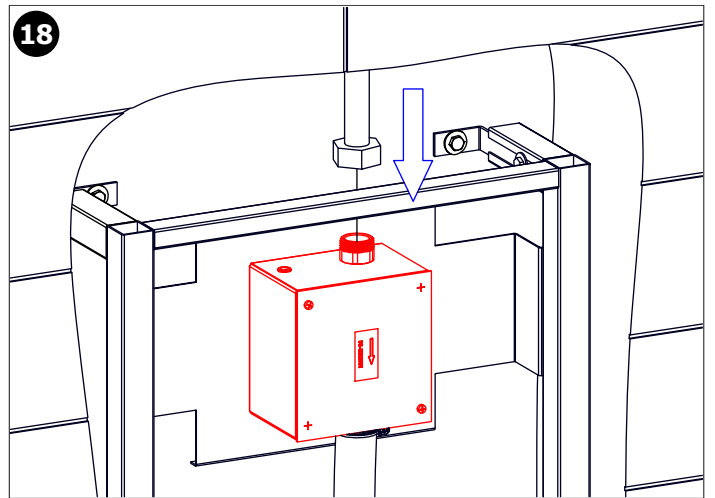
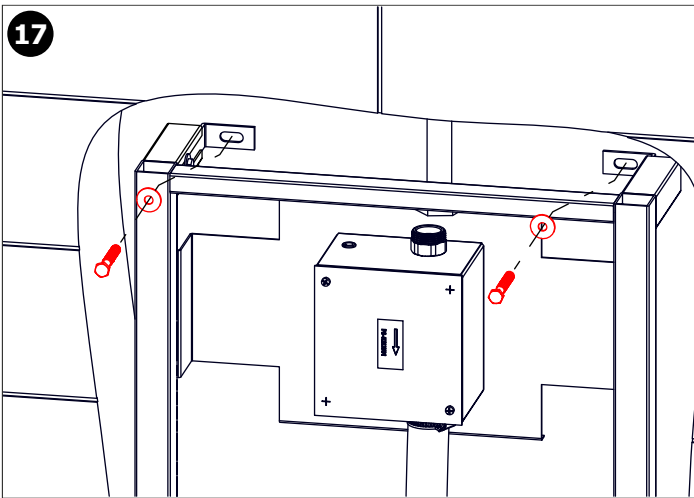
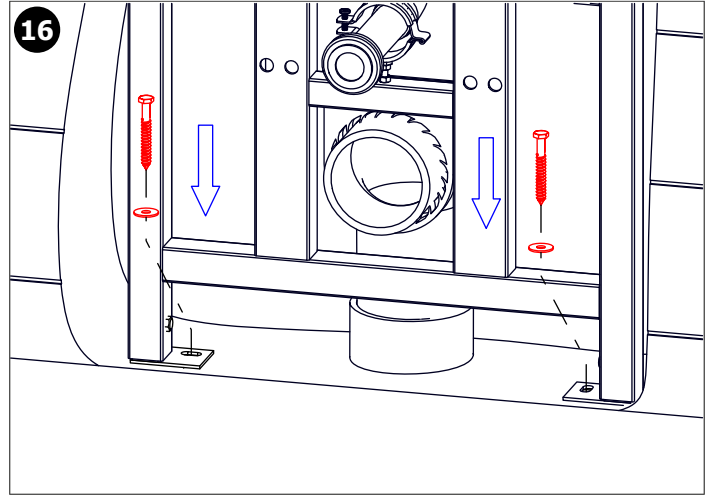
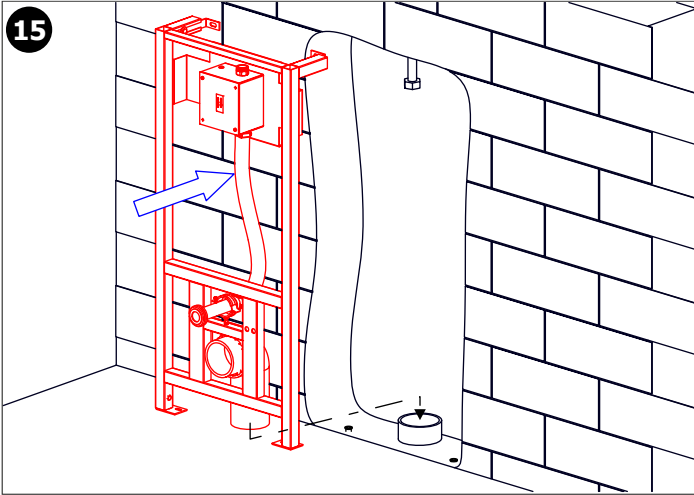
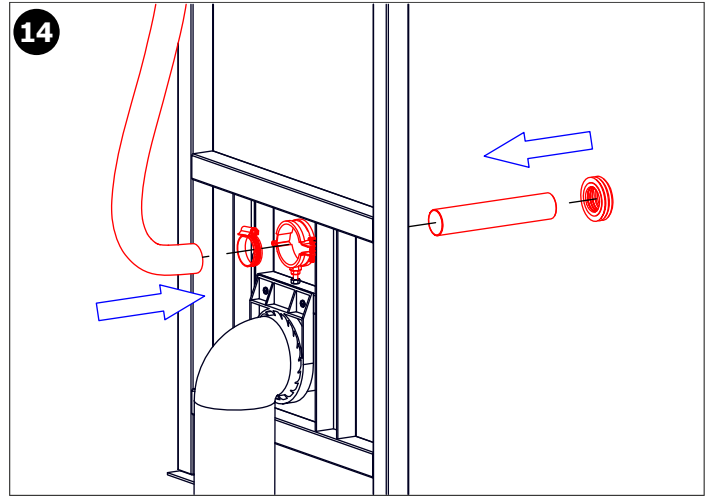
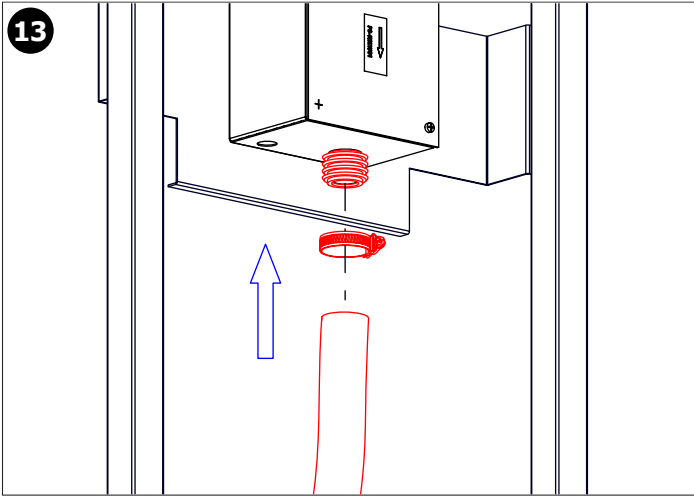

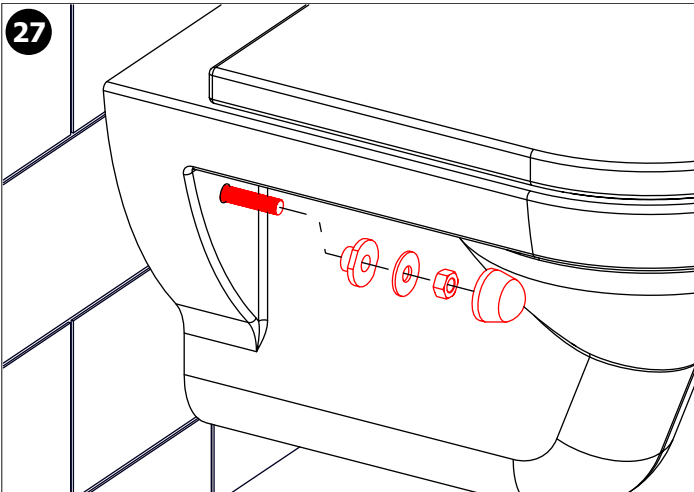
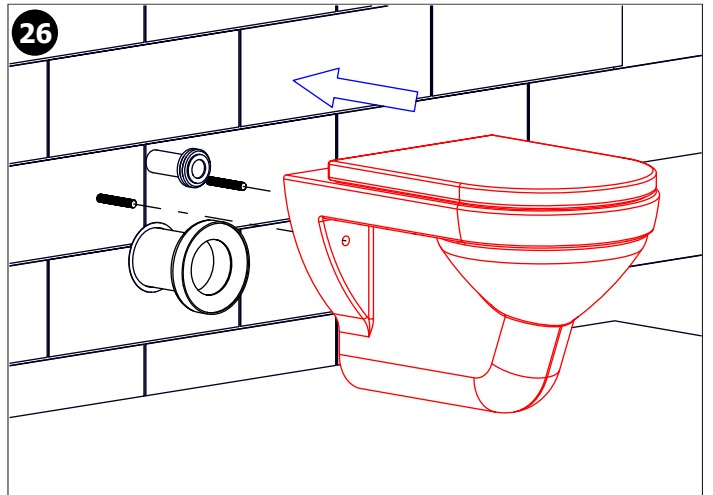
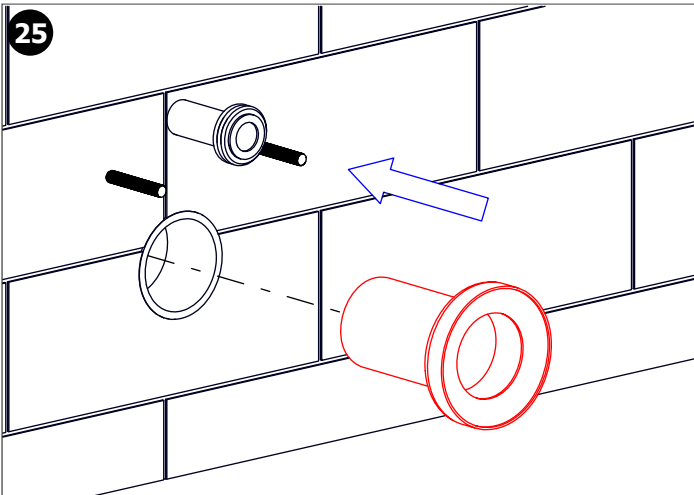
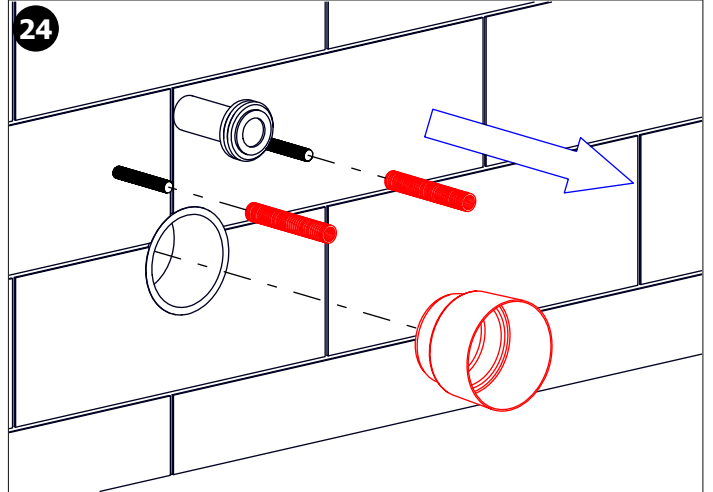
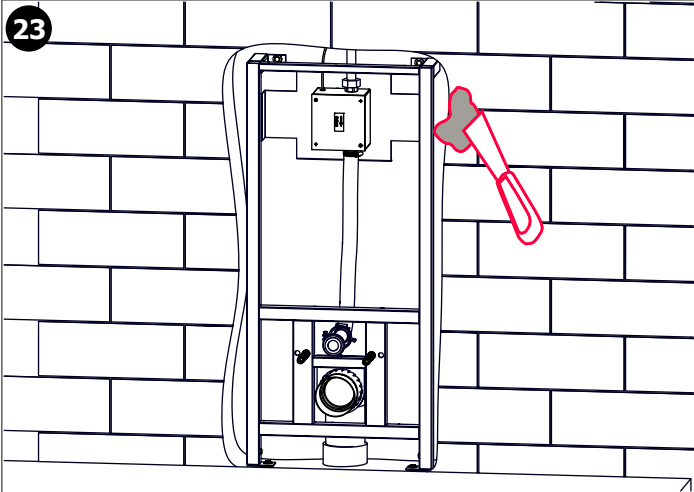
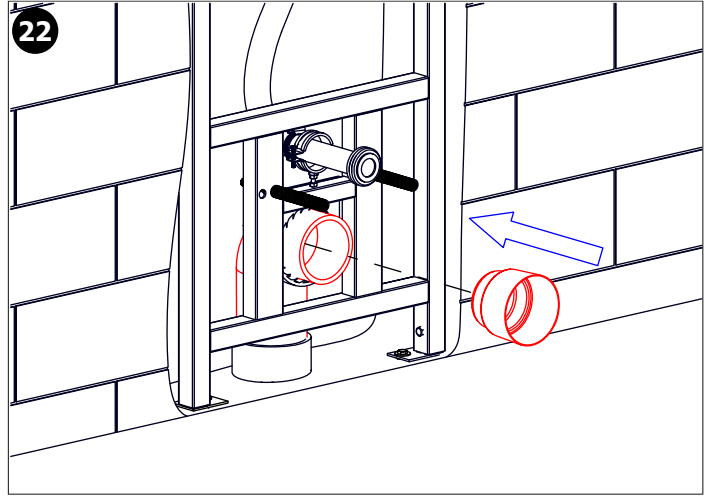
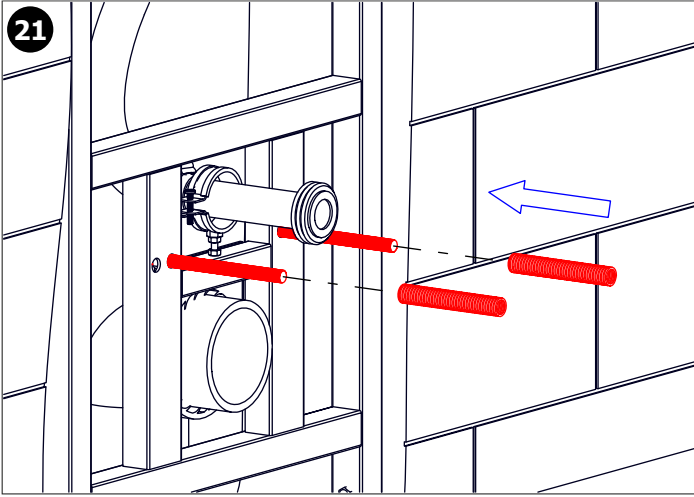

(CZ) Návod na údržbu (RU) Инструкция по уходу (RO) Instrucțiuni de întreținere (NL) Onderhoudsinstructies
 (SK) Návod na údržbu (D/A) Wartungsanleitung (ES) Instrucciones de cuidado (LT) Prižiūros instrukcija
 (GB) Instructions for maintenance (PL) Instrukcja obsługi (FR) Instructions pour l'entretien

CZ

Po vybalení výrobku je nutné s obalem postupovat podle zákona o obalech.
 Výrobce ujišťuje, že na výrobek je vydáno prohlášení o shodě v souladu se zákonem č. 22/1997 Sb.

SK

Po vybalení výrobku je potrebné s obalom postupovať podľa zákona o obaloch.
 Výrobca garantuje, že na výrobok je vydávané prehlásenie o shode v súlade so zákonom č. 22/1997 Sb.

GB

It is necessary to proceed according to the law about packaging material after unpacking of the product.
 Producer assures that this product has declaration of conformity in accordance with the regulation 73/023/EEC and 89/336/EEC.

RU

Утилизация упаковочного материала должна производиться в соответствии с законом.
 Производитель подтверждает, что у этого изделия есть Декларация Соответствия в соответствии с нормами 73/023/EEC и 89/336/EEC.

D / A

Dies ist erforderlich auf der Grundlage der gesetzlichen Bestimmungen für die Rücknahme und/oder Entsorgung von Verpackungsmaterial.
 Wir, SANELA spol. s r.o. erklären dass dieser Product ist in Übereinstimmung mit die nächste Norm: 73/023/EEC und 89/336/EEC.

PL

Po wypakowaniu urządzenia zaleca się postępować zgodnie z instrukcją obsługi.
 Producent posiada na swoje wyroby deklaracje zgodności na podstawie przepisu c.73/023/EEC i 89/336/EEC.

RO

Gestionarea ambalajelor se va realiza conform legislației în vigoare.
 Producătorul garantează că aceste produse au declarații de conformitate care respectă reglementările 73/023/EEC și 89/336/EEC.

ES

Después de desembalar el producto es necesario proceder con el embalaje en acuerdo con la ley de los embalajes.
 El productor asegura que este producto tiene declaración de conformidad de acuerdo con la ley núm. 73/023/EEC y 89/336/EEC.

FR

Conformément à la loi, Il est nécessaire de se conformer à la procédure de déballage du produit.
 Le fabricant garantie que ce produit est en conformité avec la réglementation 73/023/EEC et 89/336/EEC.

NL

Het is verplicht om de wet in acht te nemen betreffende het omgaan met verpakkingsmateriaal.
 De producten worden geleverd met een verklaring van overeenstemming met 73/023/EEC en 89/336/EEC.

LT

Išpakavus produktą būtina laikytis taisyklių atsižvelgiant į medžiagą, iš kurios pagaminta pakuotė.
 Gamintojas garantuoja, kad šis produktas turi atitiktis deklaraciją pagal reglamentą 73/023/EEC ir 89/336/EEC.